

1. Schuif de zitting in de sleuf van de rugleuning.

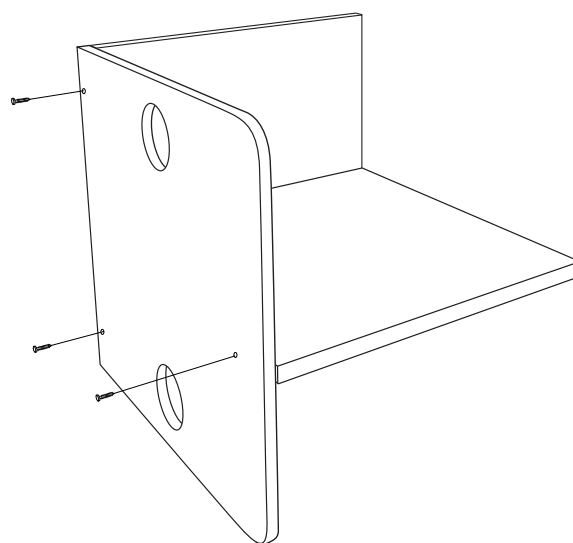

2. Schroef vervolgens één zijpaneel tegen rugleuning en zitting in de voorgeboorde gaten.

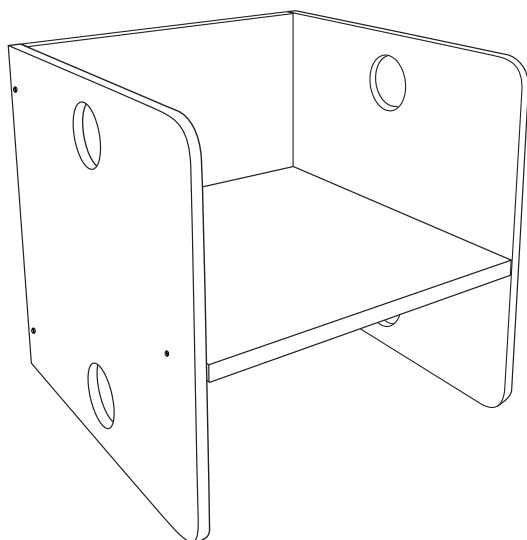

3. Schroef ook het andere zijpaneel tegen de stoel.



Draai de schroeven niet te diep in.

